

General Description

The E910.99 integrated circuit combines all required functions for a single chip Passive Infra Red (PIR) light controller.

It is designed for load switching with a transistor or a relay in 3 wire AC and DC systems.

A conventional PIR sensor connects directly to the PIR input. The pull-down resistor and DC decoupling circuitry are integrated on chip. The PIR signal is converted to a 15 bit digital value.

External potentiometers or resistors are used to set the operating parameters for sensitivity, on-time, brightness, fade, daylight sensor and environment temperature correction. The corresponding voltage levels are converted to digital values with a 4 bit resolution

All signal processing is performed digitally.

Applications

- ◆ Battery operated lights
- ◆ Solar powered garden lights
- ◆ Outdoor and indoor motion sensor lights
- ◆ High end lighting switches
- ◆ Automatic bedroom night lights
- ◆ Energy saving

Features

- ◆ Digital signal processing
- ◆ On chip supply regulator with wide operating voltage range
- ◆ Low power consumption
- ◆ Temperature compensation input
- ◆ Adjustable soft on/off switching (fading)
- ◆ Dimmer function
- ◆ PWM output
- ◆ Open Drain high voltage relay output
- ◆ Suitable for DC and AC applications

Application Circuit for a DC Sensor Light

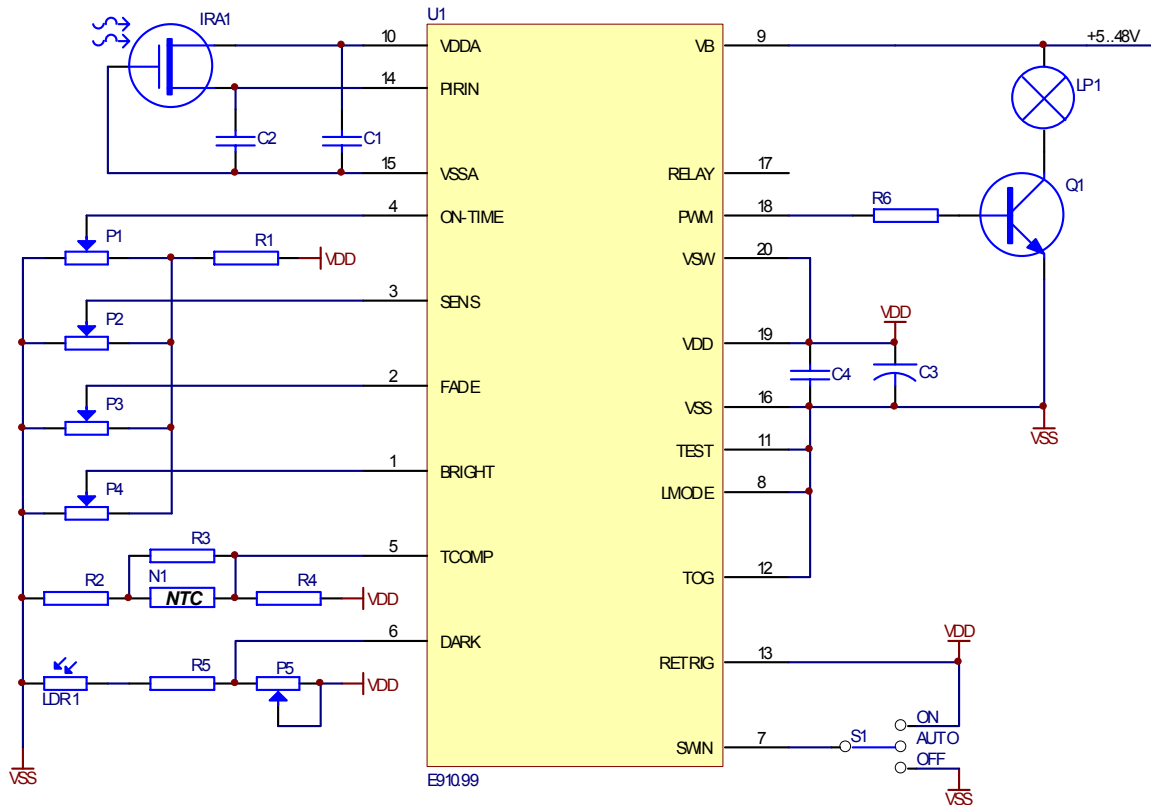

Electrical Characteristics

Absolute Maximum Ratings

Parameter	Min	Max	Unit	Remarks
Voltage on pins VB, RELAY	-0.3	48	V	
Voltage on any other pin	-0.3	7	V	
Current into any pin	-100	100	mA	One pin at a time
Storage temperature	-45	125	°C	

Table 1: Electrical Characteristics (Stresses beyond those listed above may cause permanent damage to the device. Exposure to absolute maximum ratings may affect the device reliability. ESD protection: all pins will be able to withstand a discharge of a 100pF capacitor charged to 1.6kV through a 1500Ω series resistor. Test method: MIL-STD-883D method 3015).

Operating Conditions (T=25°C, VDD=5V, unless stated otherwise)

Parameter	Min	Typ	Max	Unit	Remarks
Temperature					
Operating temperature range	-25		70	°C	
Regulator					
Supply voltage VB	5		48	V	Supply voltage
Supply current			200	μA	VB=12V (Outputs unloaded)
Regulator output voltage	3.6	4	4.4	V	
Digital Inputs, Schmitt Triggers (RETRIG, DARK, LMODE, SWIN, TEST, TOG, VSW)					
Input low voltage			20	%VDD	
Input high voltage	80			%VDD	
Input low voltage VSW			70	%VDD	
Input high voltage VSW	90			%VDD	
Pull down current on TEST, TOG		140		μA	input to VDD
Pull up current on RETRIG		140		μA	input to VSS
Leakage current on DARK, LMODE			±1	μA	input to VSS or VDD
Pull up/ pull down scanning current on SWIN			300	μA	input to VSS or VDD
Digital Outputs					
RELAY sink capability (open drain)	20			mA	VOL<1V
PWM Output low voltage			10	%VDD	ISOURCE=5mA
PWM Output high voltage	90			%VDD	ISINK=2mA
Analog Inputs					
Input leakage current (ON-TIME, SENS, FADE, BRIGHT, TCOMP)	-1		1	μA	
PIRIN resistance to VSS		70		kΩ	
PIRIN input AC voltage		100		mV	Peak-to-Peak
PIRIN input DC voltage	VSS		VDD	V	
PIRIN resolution	11	14	17	μV	Per threshold count
Oscillator and Filter					
LPF cutoff frequency		7		Hz	
HPF cutoff frequency		0.44		Hz	
Clock frequency		64		kHz	

Table 2: Operating Conditions

Detailed Description

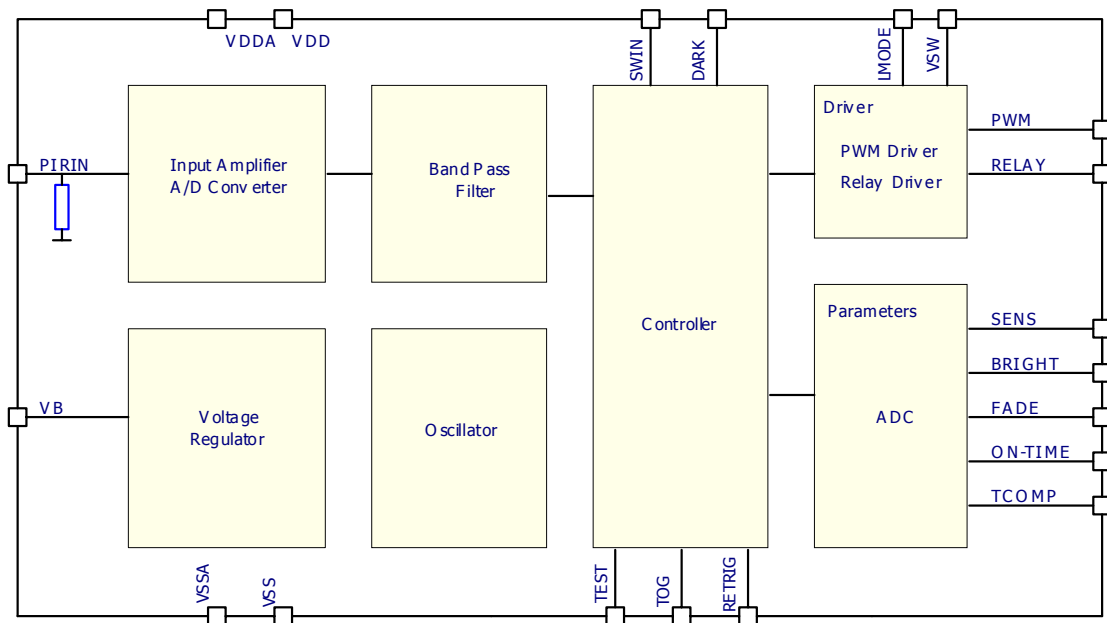

Voltage Regulator

The on-chip series regulator can accept a large variety of supply voltages, and generates a stable 4V supply for the internal circuitry. The V_{DD} pin requires a decoupling capacitor to V_{SS} .

Oscillator

The IC contains an on-chip low power oscillator. The frequency is set to 64kHz by connecting the correct resistor between CLOCK and VDD. The timing signals and cutoff frequencies of the digital filters are derived from this frequency.

PIR Sensor Input

The PIRIN input has an internal pull-down resistor. The analog to digital converter generates a digital signal from the voltage level measured on the PIRIN pin.

Band-Pass Filter

A 2nd order low-pass filter with a cut-off frequency of 7 Hz eliminates unwanted higher frequency components. This signal is then passed to a 2nd order high pass filter with a 0.44Hz cut-off frequency.

Parameter Settings

5 different parameters can be set by changing the voltages on these pins between V_{SS} and $V_{DD} * 7/32$.

SENS: Sets the sensitivity threshold required to generate a trigger condition. Refer to table 3. One count represents 14 μ V PIR voltage.

BRIGHT: Sets the maximum brightness of the light connected to the PWM output. The brightness levels are divided into 15 steps. Maximum brightness occurs at a pin voltage of $15/64 * V_{DD}$.

FADE: Sets the time it takes to switch the light on or off (soft dimming). Refer to table 3.

ON-TIME: Sets the time for the light to remain on. Refer to table 3.

Pin voltage/ V_{DD}	On time (s)	Fade time (s)	SENS threshold
7/32	2048	4.0	128
6/32	1024	3.5	64
5/32	512	3.0	32
4/32	256	2.5	16
3/32	128	2.0	8
2/32	64	1.5	4
1/32	32	1.0	2
0/32	8	0.5	1

Table 3: On-time and Fade-time

TCOMP: Temperature compensation input pin. A temperature dependent resistor network may be connected to this pin to generate voltages between $V_{DD} * 16/128$ and $V_{DD} * 31/128$. The voltage on this pin must decrease as the temperature increases. At 37°C, the voltage should be between $V_{DD} * 19/128$ and $V_{DD} * 20/128$. Internally, a TCOMP factor is selected, based on this pin voltage. This TCOMP factor is multiplied with the sensitivity threshold. Table 4 shows the relationship between TCOMP pin voltage and the TCOMP factor used by the threshold comparator. The TCOMP input may be connected to V_{SS} if the application does not require a temperature compensation function.

Pin voltage/ V _{DD}	TCOMP factor	Pin voltage/ V _{DD}	TCOMP Factor
<16/128	7/8	24/128	8/8
17/128	6/8	25/128	9/8
18/128	5/8	26/128	10/8
19/128	4/8	27/128	11/8
20/128	4/8	28/128	12/8
21/128	5/8	29/128	13/8
22/128	6/8	30/128	14/8
23/128	7/8	>31/128	15/8

Table 4: Temperature compensation factor

PWM and RELAY output drivers

The load can be switched ON and OFF with a relay, using the RELAY open collector output.

When fading and brightness control are desired, the PWM output must be used. An external transistor is normally required to switch the load current. The light intensity versus PWM ratio is different for an LED than an incandescent light, as indicated in the figure below.

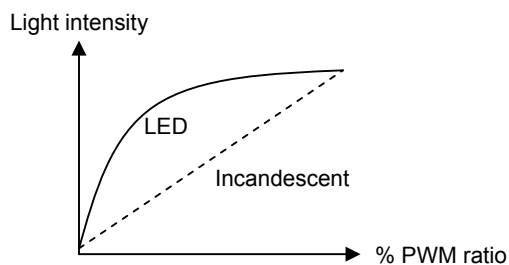

For this reason, the PWM steps are different when setting the LMODE high (for LED's) or low (for incandescent).

VSW input

The VSW input may be used to sense a slow charging relay supply voltage before enabling the outputs of the device. The RELAY and PWM outputs becomes active when the VSW > 0.9*V_{DD}. RELAY and PWM outputs becomes inactive when the VSW < 0.7*V_{DD}.

Controller: Modes of Operation

The operating modes are determined by four digital inputs. The digital inputs can be connected to V_{DD}, V_{SS} or some can be left floating, as indicated below.

Pin Name	Description
SWIN	Selects the ON-AUTO-OFF mode. V _{DD} : light permanently ON V _{SS} : light permanently OFF Floating: PIR sensor mode (AUTO)

RETRIG	Re-trigger Mode V _{DD} or floating: The timer for the on-time is restarted whenever movement is detected. V _{SS} : The light will stay on for the on-time. Movement detection is ignored during this period.
DARK ¹	Typically connected to a Light Dependant Resistor (LDR) or photo transistor, to prevent the light from switching on during daylight conditions. V _{DD} : Enable switching of the light V _{SS} : Disable switching of the light Do not leave this input floating.

Table 5: Operational parameters

¹ DARK is ignored when the light is ON in PIR sensor mode (AUTO).

Operation

Power-up Mode

Whenever the circuit is powered up, the light is switched on for the selected on-time duration. The DARK input is ignored on power-up, to allow the user to verify the installation during daylight conditions.

Trigger condition

The SENS threshold (refer to table 3) is multiplied with the TCOMP factor (refer to table 4), to obtain a temperature dependent threshold. When the filtered PIR signal exceeds this threshold, a trigger condition occurs.

Conditions for Switching the Light ON (AUTO mode)

If a trigger condition occurs and the DARK input is high, the light will be switched on. The light's brightness will increase to the selected brightness within the selected fade time.

The RELAY output is activated at the start of the fading-on cycle. The light and the relay will remain on for the duration set by the ON-TIME input.

Conditions for Switching the Light OFF (AUTO mode)

The light is switched off softly after the selected ON-TIME has elapsed, or if the DARK input senses a low voltage. The light's brightness will reduce to zero within the selected fade time. The RELAY output is switched off at the start of the fading-off cycle.

Device Pin Out

Pin No.	Name	Description
1	BRIGHT	Brightness adjustment
2	FADE	Fade time adjustment
3	SENS	Sensitivity threshold adjustment
4	ON-TIME	Light on-time adjustment
5	TCOMP	Temperature compensation input
6	DARK	Dark mode input, connected to LDR/Photodiode
7	SWIN	ON-AUTO-OFF select input
8	LMODE	LED mode select
9	VB	Supply voltage input
10	VDDA	Analog supply
11	TEST	Reserved test mode, connect to VSS
12	TTEST	Reserved test mode (TOG), connect to VSS
13	RETRIG	Retrigger mode select input
14	PIRIN	PIR sensor input
15	VSSA	Analog ground
16	VSS	Digital ground
17	RELAY	Relay output pin
18	PWM	Light output (PWM)
19	VDD	Digital VDD
20	VSW	Voltage sense input

Table 6: Device Pin Out

Component Values

Designator	Description
R1	33k
R2	20k
R3	22k
R4	180k
R5*	22k
R6*	1k to 50k, load dependent
P1,P2, P3, P4	47k
C1, C4	470nF
C2	1nF
C3	10µF
IRA1	LHI 878, Perkin Elmer
Q1*	NPN
N1	NTC 47k
LDR1*	Light dependent resistor
P5*	2.2M Trim pot

Table 7: Component Values for Application Circuit (*Suitable component values must be determined by the manufacturer)

Contact Information

Microsystems On Silicon (PTY) Ltd.
 Pretoria, South Africa
 Tel: +27 (12) 348 8367
 Fax: +27 (12) 348 1790
 Email: sales@mos.co.za

Visit our website for the latest information

Ordering Information

E910.99 SO20W (Surface mount, 300 mills)
 E910.90 DIE (Unpackaged devices)