

General Description

The E910.92 integrated circuit combines all required functions for a single chip Passive Infra Red (PIR) motion detector.

A relay and a LED output are provided for interfacing to an occupancy detector or alarm system.

One or two PIR sensors connect directly to the PIR inputs. The pull-down resistors and DC decoupling circuitry are integrated on chip. The PIR signal is converted to a 15 bit digital value.

The parameters for sensitivity, pulse count and timing are set by means of connecting the corresponding inputs to VDD, VSS or leaving them open.

The voltage level on the temperature compensation input is converted to a digital value with 4 bit resolution.

All signal processing is performed digitally.

Applications

- ◆ PIR motion detection
- ◆ Intruder detection
- ◆ Occupancy detection
- ◆ Motion sensor lights

Features

- ◆ Digital signal processing
- ◆ On chip supply regulator with wide operating voltage range
- ◆ Low power consumption
- ◆ Temperature compensation input
- ◆ Differential PIR sensor input
- ◆ Selectable relay output polarity
- ◆ Selectable pulse count and timing algorithm for motion detection

Single Sensor Application Circuit

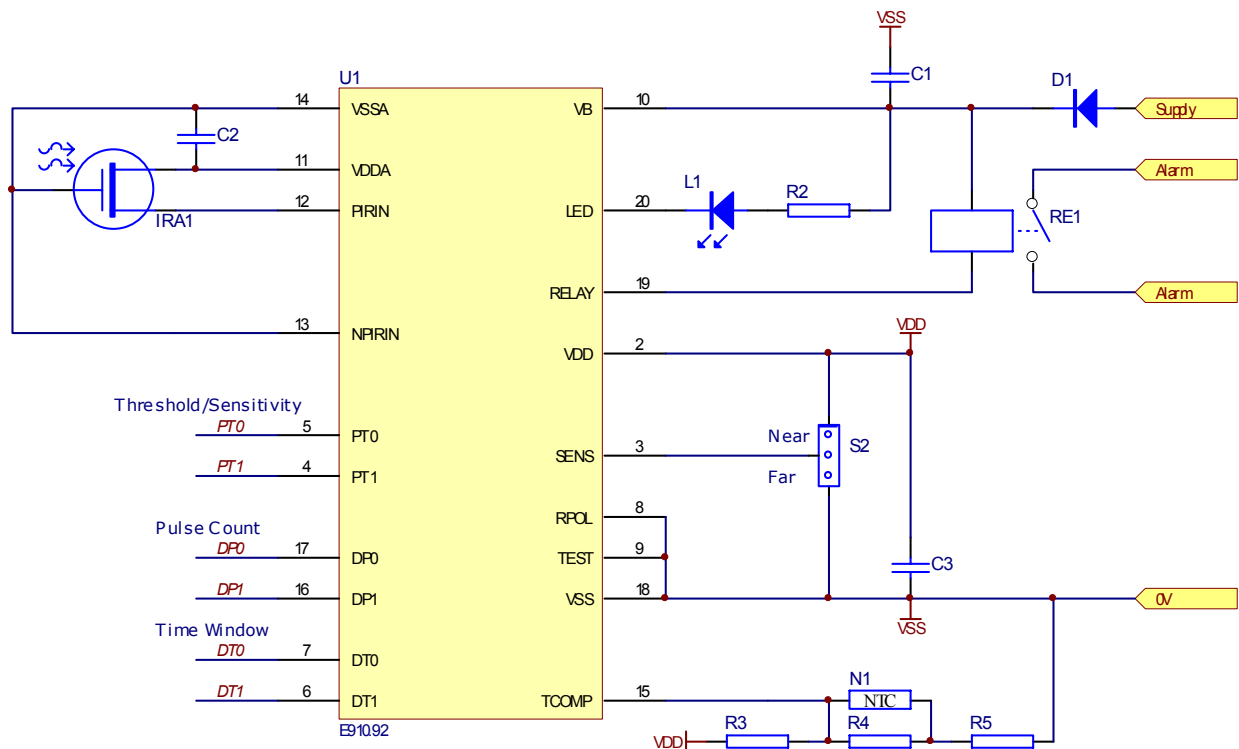

Electrical Characteristics

Absolute Maximum Ratings

Parameter	Symbol	Min	Max	Unit	Remarks
Voltage on pins VB, RELAY, LED	V _{DD}	-0.3	19	V	
Current into any pin		-100	100	mA	One pin at a time
Storage Temperature	T _{st}	-45	125	°C	

Table 1: Electrical Characteristics (Stresses beyond those listed above may cause permanent damage to the device. Exposure to absolute maximum ratings may affect the device reliability. ESD protection: all pins will be able to withstand a discharge of a 100pF capacitor charged to 1.6kV through a 1500Ω series resistor. Test method: MIL-STD-883D method 3015).

Operating Conditions (T=25°C, VDD=5V, unless stated otherwise)

Parameter	Symbol	Min	Typ	Max	Unit	Remarks
Temperature						
Operating temperature range		-25		70	°C	
Regulator						
Supply voltage	V _B	4.8		18	V	
Supply current	I _{DD}			150	μA	V _B =12V Outputs unloaded
Regulator output voltage	V _{DD}	3.6		4.4	V	
Digital Inputs, Schmitt Triggers (DP0/1, PT0/1, DT0/1, SENS, TEST, RPOL)						
Input low voltage	V _{IL}			20	%V _{DD}	
Input high voltage	V _{IH}	80			%V _{DD}	
Pull down current on TEST				140	μA	input to V _{DD}
Digital Outputs						
RELAY sink capability (open drain)	I _{OL}	25			mA	V _{OL} <1V
LED sink capability (open drain)	I _{OL}	5			mA	V _{OL} <1V
TCOMP Input						
Input voltage range		0		V _{DD}		
Input leakage current		-1		1	μA	
Input ADC range		0		V _{DD} /4		> V _{DD} /4 saturates
Input ADC resolution			4		Bits	V _{DD} /64
PIRIN / NPIRIN Inputs						
PIRIN /NPIRIN input resistance to V _{SS}			60		kΩ	
PIRIN input DC voltage range		0		V _{DD}	V	
PIRIN input AC voltage				100	mV	Peak-to-peak
ADC Resolution			14		μV	1 count
Oscillator and Filter						
LPF cutoff frequency			7		Hz	
HPF cutoff frequency			0.44		Hz	
Oscillator frequency	F _{CLK}		64		kHz	
System Clock frequency	F _{C_G}		F _{CLK} /2			

Table 2: Operating Conditions

Detailed Description

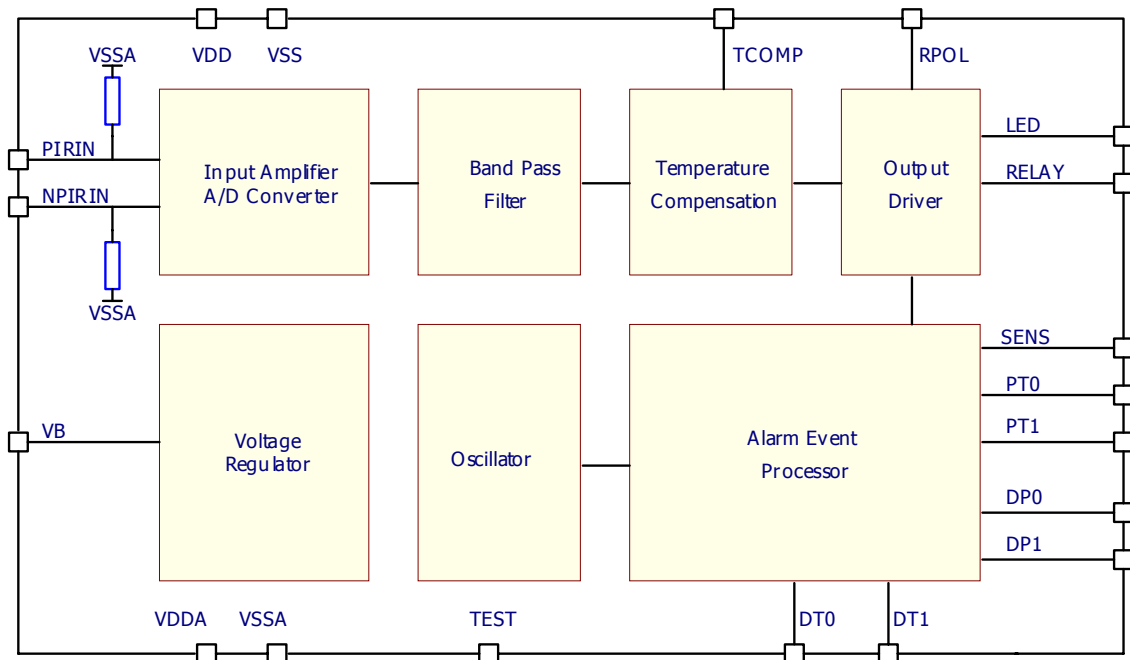

Voltage Regulator

The on-chip series regulator can accept a large variety of supply voltages, and generates a stable 4V supply for the internal circuitry. The V_{DD} pin requires a bypass capacitor to V_{SS} .

Oscillator

The IC contains an on chip low power oscillator. The frequency is set to about 64 kHz by selecting the correct resistor between OSC and V_{DD} . The timing signals and cutoff frequencies of the digital filters are derived from this frequency.

PIR Sensor Input

A differential input stage allows for up to 2 PIR sensors to be connected. The PIRIN and NPIRIN inputs have an internal pull-down resistor. The analog to digital converter generates a digital signal from the voltage level measured between the PIRIN and NPIRIN pins.

Band-Pass Filter

A 2nd order low-pass filter with a cut-off frequency of 7Hz eliminates unwanted higher frequency components. This signal is then passed to a 2nd order high pass filter with a 0.44Hz cut-off frequency.

Alarm Event Processor

The signal from the band pass filter is firstly rectified. When the signal level exceeds the selected sensitivity threshold, an internal pulse is generated and the open drain LED output transistor is switched on. The LED output remains activated while the signal is above the selected sensitivity threshold.

If immediate alarm mode (alarm on 1 pulse count) is selected, then the RELAY output is activated on every pulse, for the duration, selected by DT0 and DT1.

If TRUE-ROLL™ alarm mode (alarm on more than 1 pulse) is selected, a minimum number of pulses, selected with DT1 and DT0, would have to appear, within the selected TRUE-ROLL™ time window.

The RELAY output will remain activated as long as the alarm condition is present. The RELAY activation time is the same as the TRUE-ROLL™ time window.

The polarity of the relay output (i.e. active high or active low), can be selected with the RPOL pin.

RPOL	Relay Output
0	Active low
1	Active high

Table 3: Relay output polarity

The pins to select the sensitivity threshold, the TRUE-ROLL™ time window and the PULSE count are typically hard wired by the PIR motion detector manufacturer. The SENS input allows for a jumper, which offers a sensitivity adjustment on site.

The conditions required to raise an alarm, are controlled by the following digital inputs. These inputs must be connected to V_{DD} ('1'), V_{SS} ('0') or left open (Z), as indicated in table 4.

Pin Name		Description			
PT1	PT0	Selects the PIR controller's sensitivity threshold			
		Sensitivity	Sensitivity Threshold		
		units	SENS = 0		
		0	0	x 1	14µV Most sensitive
		0	Z	x 2	28µV
		0	1	x 4	56µV
		Z	0	x 8	112µV
		Z	Z	x 16	224µV
		Z	1	x 32	448µV
1	0	x 64	896µV		
1	Z/1	x 128	1.792mV Least sensitive		
DP1	DP0	Selects the amount of pulses required for an alarm condition.			
		0	0	1 immediate alarm mode	
		0	1	2 TRUE-ROLL™	
		1	0	3 alarm mode	
1	1	4			
DT1	DT0	Selects the TRUE-ROLL™ time window			
		0	0	2 s	
		0	1	4 s	
		1	0	8 s	
1	1	16 s			
SENS		Connection to V _{DD} doubles selected threshold			

Table 4: Alarm event processor input settings

TCOMP: Temperature compensation input pin. A temperature dependent resistor network may be connected to this pin to generate voltages between $V_{DD} \cdot 16/128$ and $V_{DD} \cdot 31/128$. The voltage on this pin must decrease as the temperature increases. At 37°C, the voltage should be between $V_{DD} \cdot 19/128$ and $V_{DD} \cdot 20/128$. Internally, a TCOMP factor is selected, based on this pin voltage. This factor is multiplied with the sensitivity threshold. Table 5 shows the dependency of the pin voltage and the TCOMP factor used by the alarm event processor.

Pin voltage/ V _{DD}	TCOMP factor	Pin voltage/ V _{DD}	TCOMP Factor
<16/128	7/8	24/128	8/8
17/128	6/8	25/128	9/8
18/128	5/8	26/128	10/8
19/128	4/8	27/128	11/8
20/128	4/8	28/128	12/8
21/128	5/8	29/128	13/8
22/128	6/8	30/128	14/8
23/128	7/8	>31/128	15/8

Table 5: Temperature compensation factor

Example of TRUE-ROLL™ time window set to 4s and pulse count to 3.

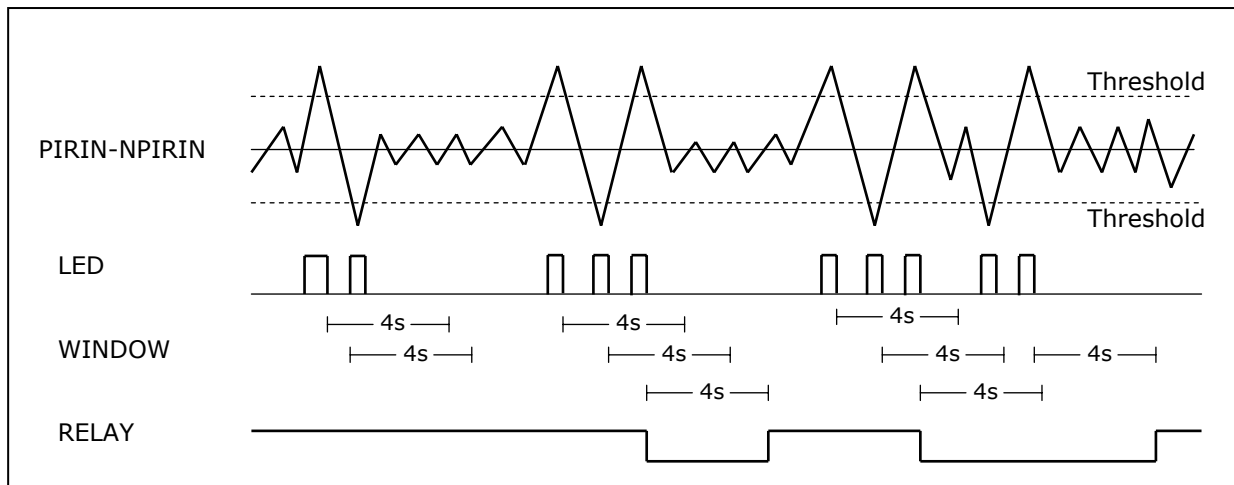

Device Pin Out

Pin No.	Name	Description
1	N C	Not connected
2	V _{DD}	Regulated supply voltage
3	SENS	Range select
4	PT1	Sensitivity selection
5	PT0	Sensitivity selection
6	DT1	TRUE-ROLL™ time window select
7	DT0	TRUE-ROLL™ time window select
8	RPOL	RELAY Pin polarity selection
9	TEST	Reserved, connect to V _{SS}
10	VB	Unregulated supply voltage
11	V _{DDA}	Regulated supply voltage, only connect PIR element to this pin
12	PIRIN	PIR sensor input
13	NPIRIN	Negative PIR sensor input
14	V _{SSA}	Negative supply voltage, only connect PIR element to this pin
15	TCOMP	Temperature Compensation Input
16	DP1	Pulse count selector
17	DP0	Pulse count selector
18	V _{SS}	Negative supply voltage
19	RELAY	Relay Output (open drain)
20	LED	LED Output (open drain)

Table 6: Device Pin Out

Component Values

Designator	Description
R2	1.2kΩ
R3	180kΩ
R4	33kΩ
R5	18kΩ
N1	47kΩ NTC
C1	10μF/25V, electrolytic
C2, C3	820nF, ceramic
D1	1N4007, optional protection diode
IRA	LHI 878, PIR sensor

Table 7: Component Values for Application Circuit

Contact Information

Microsystems On Silicon (PTY) Ltd.
Pretoria, South Africa
Tel: +27 (12) 348 8367
Fax: +27 (12) 348 1790
Email: sales@mos.co.za

Visit our website for the latest information

Ordering Information

E910.92-SO20W (20 pin Surface mount, 300 mil width)
E910.92 DIE (Unpackaged devices)